

Constellation-X Soft X-Ray Telescope Segmented Optic Assembly and Alignment Implementation

Jason H. Hair^{1a}, Jeffery Stewart^{2a}, Robert Petre^{3a}, William W. Zhang^{4a}, David A. Content^{5a}, Timo T. Saha^{6a}, William A. Podgorski^{7b}, Paul Glenn^{8c}, Mark L. Schattensburg^{9d}, Ralf Heilmann^{10d}, Yanxia Sun^{11d}, Giriraj Nanan^{12e}

^aNASA – Goddard Space Flight Center; ^bSmithsonian Astrophysical Observatory; ^cBauer Associates, Inc.; ^dMassachusetts Institute of Technology; ^eSwales and Associates, Inc.

ABSTRACT

The Constellation-X mission will perform X-Ray science with improvements in resolution and effective area over its predecessor missions. The primary instrument on the Constellation-X spacecraft is the Soft X-Ray Telescope (SXT). The SXT is a 1.6m diameter grazing incidence mirror assembly comprised of approximately 4000 optic elements. In order for the optic elements to work together to achieve the required 15 arcsec resolution for the telescope, each optic must be aligned very precisely.

To enable the alignment of the optic elements to the required tolerances, new technology must be developed through a series of technology demonstrators. The first step in this process is the production of the Optical Alignment Pathfinder (OAP). The OAP represents a small section, or module, of the complete SXT and has been designed to facilitate the evaluation and development of the optic element support, alignment, and adjustment concepts, processes, and procedures. To do this, one pair of optic elements, primary and secondary, will be aligned using optical alignment methods using the Centroid Detector Assembly (CDA) and Interferometry. Ten Optic Adjustment Arms will support the optic elements such that their position and figures can be adjusted. Currently, one section, the primary section, of the OAP has been assembled and is awaiting the installation of an optic element for testing.

Keywords: Segmented X-Ray optics, Centroid Detector Assembly, interferometry, optical alignment methods, optic support, precision adjustment, delicate assembly processes

¹jason.hair@gssc.nasa.gov; phone 1 301 286 5390; www.gsfc.nasa.gov; NASA – Goddard Space Flight Center, Code 543, Greenbelt, MD, USA 20771; ²jeffrey.w.stewart.1@gssc.nasa.gov; phone 1 301 286 3218; www.gsfc.nasa.gov; NASA – Goddard Space Flight Center, Code 543, Greenbelt, MD, USA 20771; ³robert.petre.1@gssc.nasa.gov; phone 1 301 286 3844; www.gsfc.nasa.gov; NASA – Goddard Space Flight Center, Code 662, Greenbelt, MD, USA 20771; ⁴william.w.zhang.1@gssc.nasa.gov; phone 1 301 286 6230; www.gsfc.nasa.gov; NASA – Goddard Space Flight Center, Code 662, Greenbelt, MD, USA 20771; ⁵david.a.content.1@gssc.nasa.gov; phone 1 301 286 7382; www.gsfc.nasa.gov; NASA – Goddard Space Flight Center, Code 551, Greenbelt, MD, USA 20771; ⁶timo.t.saha.1@gssc.nasa.gov; phone 1 301 286 2863; www.gsfc.nasa.gov; NASA – Goddard Space Flight Center, Code 551, Greenbelt, MD, USA 20771; ⁷wpodgorski@cfa.harvard.edu; phone 1 617 495 7363; cfa-www.harvard.edu/sao-home.html; Smithsonian Astrophysical Observatory, 60 Garden Street, MS 5, Cambridge, MA, USA 02138; ⁸paul@bauerinc.com; phone 1 781 235 8775; www.bauerinc.com; Bauer Associates, Inc., 888 Worcester Street, Suite 30, Wellesley, MA, USA 02482; ⁹marks@space.mit.edu; phone 1 617 253 3180; snl.mit.edu; Space Nanotechnology Laboratory, Massachusetts Institute of Technology, 70 Vassar Street, Room 37-487, Cambridge, MA, USA 02139; ¹⁰ralf@space.mit.edu; phone 1 617 253 8764; snl.mit.edu; Space Nanotechnology Laboratory, Massachusetts Institute of Technology, 70 Vassar Street, Room 37-421, Cambridge, MA, USA 02139; ¹¹yxun@mit.edu; phone 1 617 253 5877; snl.mit.edu; Space Nanotechnology Laboratory, Massachusetts Institute of Technology, 70 Vassar Street, Room 37-432, Cambridge, MA, USA 02139; ¹²giriraj.nanan.1@gssc.nasa.gov; phone 1 301 285 6802; www.swales.com; Swales and Associates, NASA – Goddard Space Flight Center, Code 543, Greenbelt, MD, USA 20771

1. INTRODUCTION

The Constellation-X mission utilizes an array of spacecraft to act as one observatory to perform X-Ray astronomy. Constellation-X will provide greatly increased effective area and resolution over existing X-Ray observatories, such as Chandra, through advances and application of new technologies. One area where new technology must be applied is in the manufacture of the Soft X-Ray Telescope (SXT), the primary instrument.

In the current design, Constellation-X will be an array of four spacecraft, each with one SXT, as shown in Fig. 1 below.

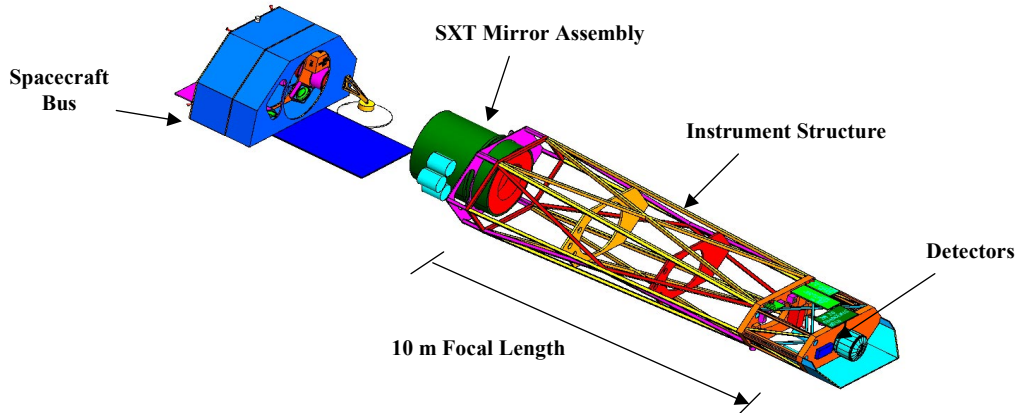

Fig. 1: Constellation-X spacecraft configuration.

Each SXT utilizes a grazing incidence telescope design and has a diameter of 1.6m with a length between 0.4m and 0.6m, depending on the final telescope design. Within the 1.6m diameter, there will be 170 to 230 concentric optic shells, each with a different radius. Rather than using concentric 'full shell' optic shells, the optic shells are 'segmented' into 60 degree, and then 30 degree sections. Fig. 2 below shows an SXT with the segmented optic shells. The length of the SXT is split in half such that there are in effect two sets of shells, primary and secondary, for each radius with each optic element 20cm to 30cm in length. The second set of shells has a slightly larger angle with respect to the optical axis than the first set in order to focus the X-Rays to a focal length of 10m. The result is that there are 3012 to 4140 optic elements in each SXT.

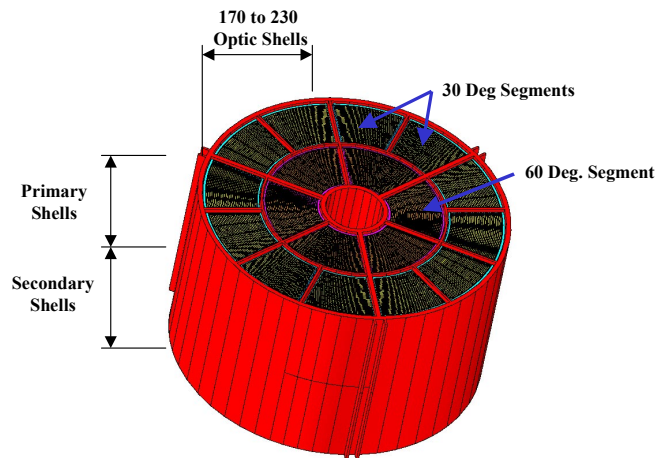

Fig. 2: Spectroscopy X-Ray Telescope (SXT).

In order for the 4000 optic elements to work together to achieve the required resolution of 15 arcsec for the telescope, each element must be aligned to tolerances in the range of 0.5 μ m. The consequence of this tolerance and the scale of the telescope is that the assembly process becomes highly complex. To aid in the assembly and alignment of all the optic elements, the SXT will be constructed in a modular manner as shown in Fig. 3 below. First, the appropriate optic shell segments are installed and aligned into their respective 60 and 30 degree modules. One 60 degree module, inner module, and two 30 degree modules, outer modules, are assembled to make a 60 degree wedge of the SXT. Six wedges are then assembled to make complete SXT.

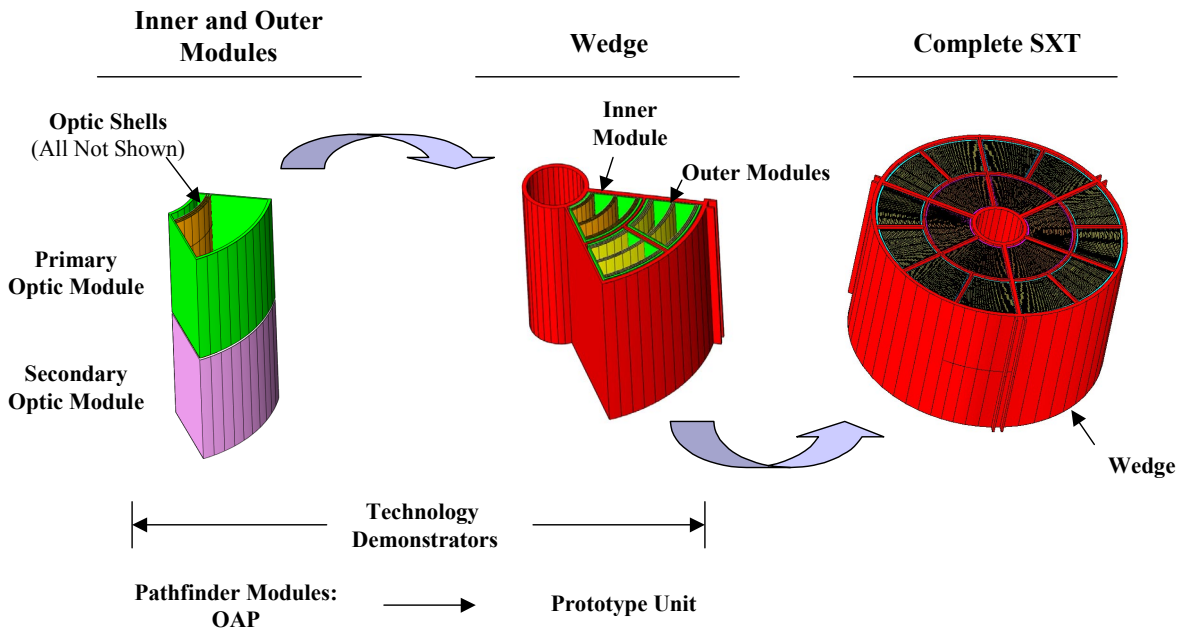

Fig. 3: SXT modular construction.

Currently Constellation-X is in the formulation phase. The overall mission concept and spacecraft configurations are being explored in the form of paper studies. However, due to its criticality and complexity, the SXT, and the new technology supporting its ultimate completion, is being developed through technology demonstrators. The technology demonstration process involves building the hardware required to construct a limited number of modules of the SXT and aligning optics to the required tolerances within these modules. The completion of the technology demonstration will result in a prototype unit, which will consist of a wedge of the SXT populated with 27 pairs of optics, as shown in Fig. 3 above. Before the prototype design is complete, a number of pathfinder modules will be constructed and various pairs of optics aligned within them as proofs of concept.

The purpose of the technology demonstration progression is to answer and test many of the questions regarding the methodology for aligning the optic elements to the required tolerances, material selection, and overall fabrication processes. For further information about the design of the SXT and the technology demonstration process, see “*Constellation-X Spectroscopy X-Ray Telescope (SXT)*” from this conference by R. Petre, et al.

The technology demonstration process is currently taking its first step, the development of the first pathfinder module, the Optical Assembly Pathfinder (OAP). The OAP consists of the primary and secondary portions of an inner module, inside of which one primary and one secondary optic will be aligned. The primary section of the OAP module, including the optic support and adjustment hardware, has been completed and the secondary section is under construction. Optics will be aligned within the OAP using an optical alignment device, the Centroid Detector Assembly (CDA). The goals of the OAP are to test the optic support and adjustment hardware and procedures as well as the ability of the CDA to align

optics in this manner. This paper will focus on the assembly and alignment techniques of the optic elements inside the OAP, including descriptions of the alignment tools, optic support and adjustment mechanisms, and OAP design and fabrication.

2. OAP REQUIREMENTS AND GOALS

The SXT performance requirements, effective area and spatial resolution, have been derived down to the alignment requirements for each telescope wedge, module, and optic element, including the figure of the optic elements. These derived requirements have been translated into requirements for the SXT, including assembly and operating temperature, optic and SXT structure materials, optic element alignment methods, and optic element support points. For more information on the requirements breakdown, see “*Constellation-X Soft X-Ray Telescope Assembly and Alignment*” from this conference by W. Podgorski, et al.

The technology demonstration process has been designed to develop the technology required to, among other things, align the optic elements while maintaining their figure within tolerances. As the first step in this development process, the OAP focuses on evaluating the concepts that have been derived to help meet this aim.

One major concept that has significant implications in the current SXT design is that the most effective way to support and adjust each optic element’s figure is through five points on the top edge and five points on the bottom edge¹. This concept has been supported by analysis, but the OAP will begin to investigate its validity. To do this, the OAP shall provide means to support and facilitate the adjustment of optic element figure at the ten locations, five on top and five on bottom.

In addition to meeting the requirements to evaluate the concept above, the OAP shall:

- Accommodate one Primary and one Secondary optic 20cm in length with radii near 25cm;
- Represent an inner module;
- Be made of Aluminum;
- Facilitate optic alignment by the CDA; and,
- Facilitate the achievement of these goals:
 - The determination of a single optic alignment process; and,
 - The creation of a plan to establish the optic absolute radius.

3. OPTICAL ASSEMBLY PATHFINDER

The purpose of the Optical Assembly Pathfinder (OAP), as the first step in the technology development process for the SXT, is to test concepts that have been developed for the support, adjustment, and alignment of the optic elements for the SXT. The OAP has been designed to meet these aims, including the requirements from above, and is shown in Fig. 4 below.

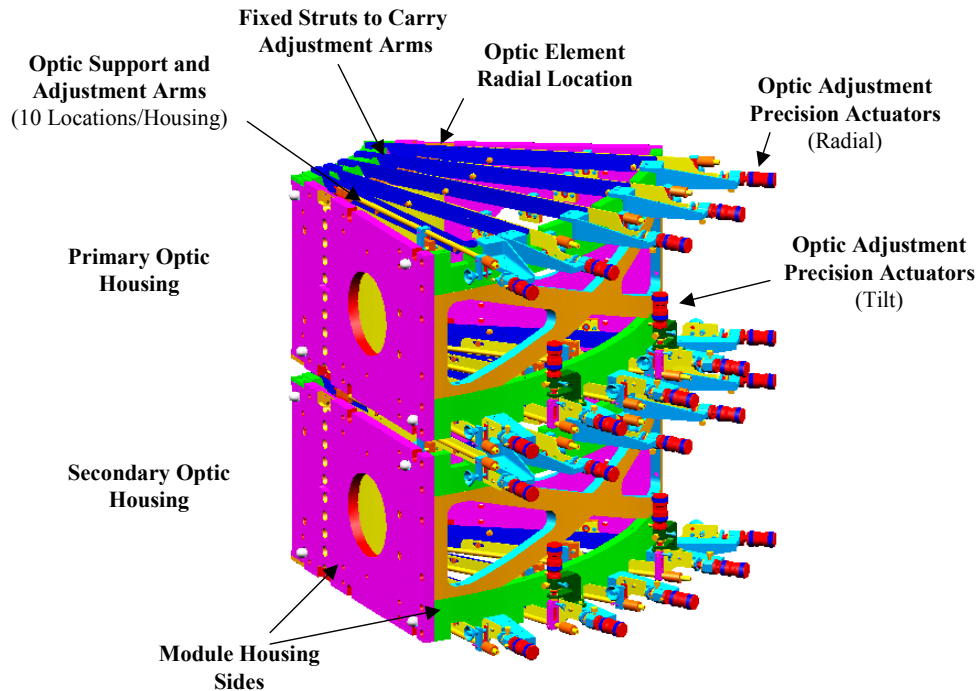

Fig. 4: Optical Assembly Pathfinder.

The OAP is an aluminum version of an inner module for the SXT that accommodates one primary optic and its respective secondary optic. Aluminum was chosen for speed and ease of manufacture. The OAP provides 10 locations of support for each of the two optic elements, five on top and five on bottom of each optic. All ten locations can be adjusted radially to control the optic element positions, tilts, and figures. Two of the bottom adjustment locations for each optic provide adjustability in to control vertical positions and tilts of the optic elements. The OAP is capable of containing optic elements near 25cm radius that are 20cm tall.

The OAP is currently being prepared for optic element assembly and alignment. The Primary Optic Housing has been completely assembled and is awaiting the completion of the Secondary Optic Housing, which will follow shortly. Alignment testing of the optic element within the OAP should begin in August 2002, when the OAP is completely assembled, the optic elements are integrated into the OAP, and the alignment metrology has been set up.

3.1 Optic Support and Adjustment

The optic element support and adjustment concept is one of the key concepts that the OAP has been designed to evaluate. Analysis has shown that the potentially best way to support and adjust the optic element figure, tilt, and position is through five points at the top and five points at the bottom of the optic element¹. The OAP provides these ten interface locations, which are evenly spaced and radial along the top and bottom ends of the optic elements as shown in Fig. 4 above.

As important as the location where the optic element is supported is how it is supported and adjusted. The optic elements must be supported at an interface that will not cause local distortion in the optic figure. When the position of each optic element support location is adjusted, it must be adjusted radially in very small increments in a manner that will not cause unintended distortions in the optic element.

To address these issues, the Optic Adjustment Arms, as shown in Fig. 5 below, were developed to support and facilitate the adjustment of the optic elements. The Optic Adjustment Arms consist of two portions, one fixed and one that pivots.

The Sliding Strongback is attached to fixed struts on the OAP such that the Adjustment Arm is permitted only to slide radially, in the direction of the strut. A precision actuator pushes and pulls on the Sliding Strongback to control the radial location of the Adjustment Arm. The pivoting portion of the Adjustment Arm is attached to the Strongback through a Bearing Block and a Spherical Bearing. The Spherical Bearing allows the rest of the Adjustment Arm to pivot in all directions. The benefit of the ability to pivot is that the distortions induced by adjusting the optic are minimized as the Arms can float such that they only control the radial location of the optic element. If the ability to pivot is not desired, a detent pin can be used to lock the Adjustment Arm in a rigid position.

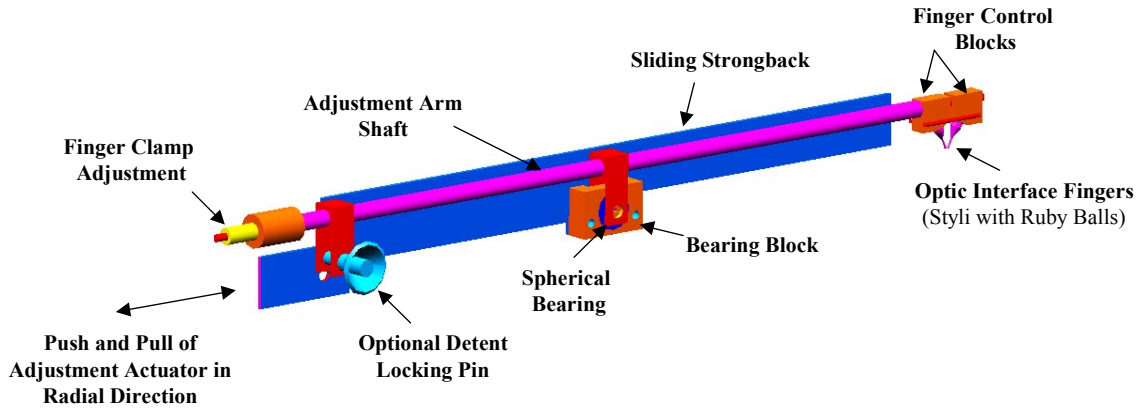

Fig. 5: Optic Adjustment Arms.

The pivoting portions of the Adjustment Arm are balanced about the spherical bearing. Probes, styli, from a Coordinate Measuring Machine with 1mm diameter ruby balls are used to interface with the optic elements, as shown in greater detail in Fig. 6 below. The optic element is clamped between the ruby balls with minimal distortion. The styli are attached to Finger Control Blocks and a threaded rod into one of the Finger Control Blocks controls the separation, and thus the clamping force, of the styli.

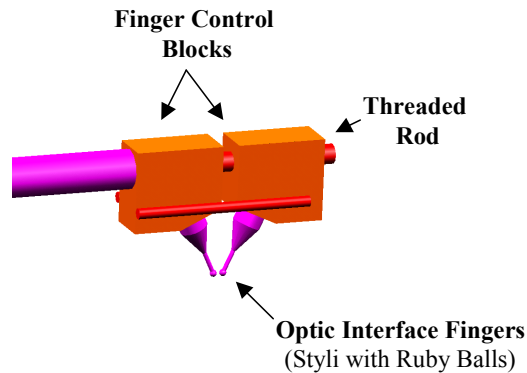

Fig. 6: Detail of Optic Interface Fingers.

The Adjustment Arms that control the vertical position and tilt of the optic elements are nearly identical to the standard Adjustment Arms. One difference is that one of the Finger Control Blocks has a small foot that the bottom of the optic element will contact, as shown in Fig. 7 below. The other difference is that a precision actuator is used to control the pivot of the Adjustment Arm about the spherical bearing to control the optic element vertical position.

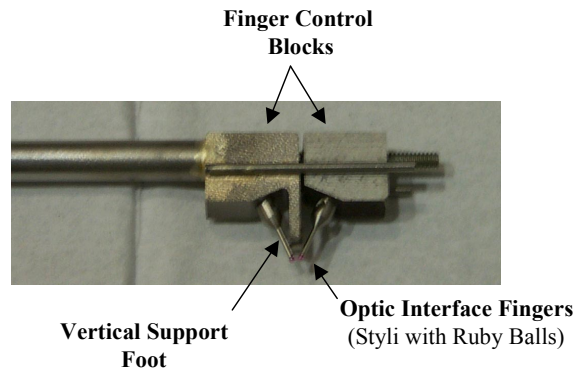

Fig. 7: Detail of Optic Interface Tilt Control Fingers.

The precision actuators that are used to control the Adjustment Arms are Newport Corporation model DS-4F with $0.02\mu\text{m}$ sensitivity, 8mm of coarse travel, and 0.3mm fine travel.

3.2 Optic Element Alignment Process

The optic element alignment process is the other key concept that the OAP has been conceived to evaluate. Optical metrology techniques will be relied upon to perform the fine alignment required to meet the stringent resolution requirements of the SXT. The very small tolerances of the optical element positions and tilts preclude the complete reliance on mechanical interfaces to meet the specifications. Two types of optical metrology will be used on the OAP, figure analysis by interferometry and centroid detection by the CDA. The goal of aligning optic elements within the OAP using these two methods is to develop the procedures needed to use each method effectively such that they can be applied to the next steps in the technology demonstration process, eventually leading to the Prototype Unit.

The process of aligning the optic elements within the OAP begins with the coarse positioning of the optic when it is installed into the OAP. A portable Coordinate Measuring Machine (CMM), in this case a Faro Gold Arm, will be used to align the optic elements to within $50\mu\text{m}$ of their true position with respect to the OAP telescope axis. At this point, the CDA and Interferometer will take over for fine alignment. The CDA will measure the position and tilt of the optic element and adjustments will be made at the 10 support locations using the precision actuators based on the analysis of the data given by the CDA. The Interferometer will monitor the effect of the adjustment and alignment process on the optic element figure and adjustments will be made as necessary. This process will be performed for the primary optic first, and then the secondary optic will be aligned to the primary using similar techniques.

3.2.1 Centroid Detector Assembly

In order to characterize the misalignments and certain distortions of the Con-X optics, Centroid Detector Assembly (CDA), originally developed by Bauer Associates, Inc. for Chandra, will be used. For Chandra, the CDA demonstrated sensitivities better than 0.1 arcsec., which is well within the sensitivity required for the SXT. The CDA has been previously documented in some detail², but we briefly summarize the instrument below.

The CDA is based on a modified Hartmann approach. This technique was used in a simpler form much earlier on the High Energy Astrophysical Observatory (HEAO-B)³. Hartmann approaches in general work by testing small sub-apertures of a system to see where in the focal plane they cast an image. Any lateral errors in the location of the image indicate a corresponding wavefront slope error at the sub-aperture being tested. By testing many sub-apertures, these slope errors can be integrated to give the total wavefront error.

In a standard Hartmann approach, many sub-apertures, such as a ring of sub-apertures, are tested simultaneously, first slightly on one side of the focal plane, and then slightly on the other side. In modified Hartmann approach used by the CDA, a pencil beam is sent from the nominal focal point of the telescope, through the telescope, to a retro-reflection flat,

back through the telescope, and back again to the nominal focal point, where its lateral location is measured. A conceptual view of this arrangement is shown in Fig. 8 below.

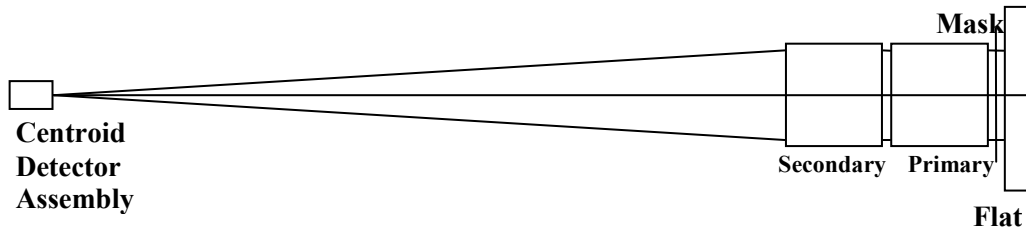

Fig. 8: Conceptual layout of the Centroid Detector Assembly in use aligning a mirror pair.

The CDA consists essentially of a laser source, beam steering optics to point the beam at various places in the telescope's aperture, a quadrant cell detector to sense the lateral location of the return beam, and beam splitting optics to separate the outgoing and return beams. All components are mounted in a rectangular box with a total length of 800mm with kinematic attachment points. Fig. 9 below shows a schematic of the internal configuration.

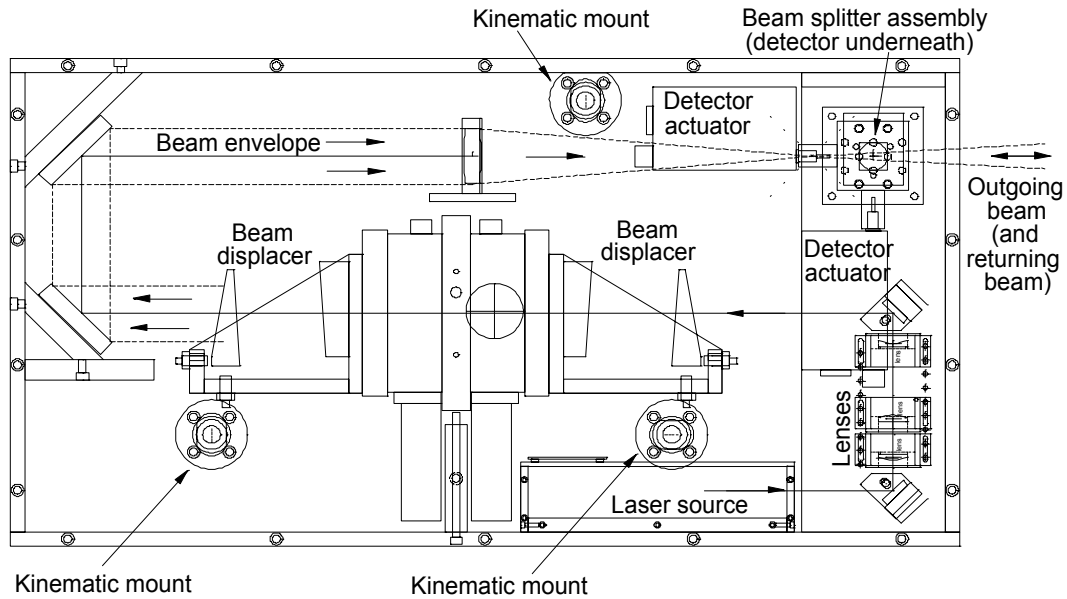

Fig. 9: Schematic of the internal configuration of the CDA.

The laser source is a combination of two diode lasers, each feeding one polarization component into a single-mode, polarization-preserving fiber. The fiber is permanently attached to the beam combining optics on one end, and to a collimating lens on the other end. Thus, two identical and coaxial beams emanate from the collimating lens, each extremely clean and nearly Gaussian. One beam is for a reference leg that is internal to the CDA and the other for the external test. The beams are independently controllable and detectable, so that there is complete external control over which leg of the instrument is operating. The reference leg serves to monitor the position that the returned beam *would* have if it were returning from a "perfect" test piece. In this way, drifts of the laser source and the internal optics can be removed from the measurement of the position of the returned test beam.

In order to be able to probe the telescope at any arbitrary aperture location, a pair of independently tilted and rotating windows is used in the collimated space before the objective lens that focuses the outgoing rays onto the CDA's virtual source point. Each tilted window is in fact constructed of a pair of oppositely oriented wedges, each operating at the angle of minimum deflection for stability. The opposite orientation of the wedges within a pair serves to displace the beam laterally while leaving its pointing direction unchanged. The use of two independently rotatable wedge pairs allows any composite displacement from zero to twice that of a single pair, with the composite displacement lying in any desired direction.

Another important feature of the CDA is its ability to perform real time calibrations of the detector, using the actual images. To accomplish this, the quadrant cell detector is mounted on a motorized x-y stage with 0.1 μ m resolution. This allows the stage to be moved over a fine grid of known dimensions while a stationary image is present. The x- and y-positions of the stage can then be expressed as functions of the x- and y-signal values obtained from the quadrant cell. A least squares fit to a polynomial series is performed, which then defines subsequent conversions from detector values to spot positions. In this way, the size and shape of the apertures at the telescope do not affect the CDA's ability to quantify the focal plane positions of the returning beams.

3.2.2 Interferometry

Normal incidence optical interferometry is used as a metrology tool both on free state optics and those installed in the OAP. A plane reference wavefront is used to test the axial figure error. A conical optic element with no axial error, with a correctly aligned wavefront, will return a good null error wavefront. As the beam is only normal to the test optic at one azimuth, only profiles can be obtained using this method. Fig. 10 below shows the test geometry using a 6in expanded beam on a mandrel; the same test works for either mandrels or optic elements. A custom-built 20cm beam expander is used for the OAP optic elements.

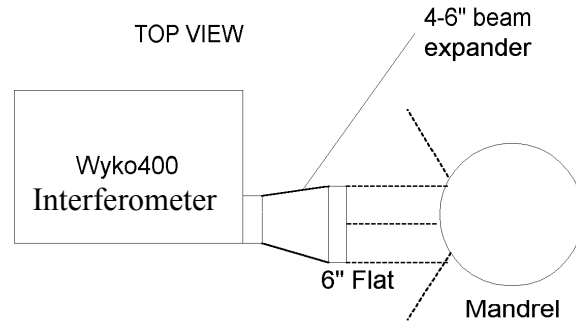

Fig. 10: Geometry for Interferometric testing of mandrels and optic elements.

As the OAP and SXT optic elements are of true Wolter-I design, a slight wavefront error exists ($\sim 2.8 \mu\text{m P/V}$) due to the Wolter axial sag, as compared to a best-fit cone. However, for the purposes of the SXT, higher order terms beyond curvature are negligible.

In-situ interferometric testing will be performed once the optic elements have been installed into the OAP. Steer-able fold flats (5x23 cm) will be used to bring the beam to the integrated optic elements in normal incidence in order to repeat the axial figure measurement. This test will facilitate the comparison between the free state of the optic and the distortions induced by the supports of the OAP. In conjunction with the CDA, this should allow the separation of figure from alignment errors.

Additionally, after the formed glass substrates for the optic elements are formed, they are tested to screen the substrates to select the best ones for replication. As the forming mandrels are conical, the substrates are compared to the best-fit cone. Then, the fully replicated foils are compared to the nominal Wolter curvature to assess the axial figure errors of the optic elements in their free state.

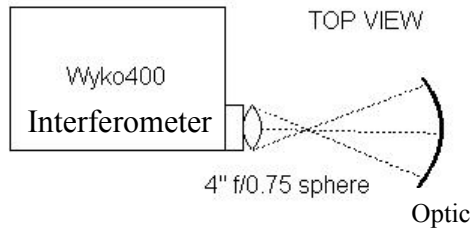

Fig. 11: Azimuthal figure error test geometry.

A second test geometry, as shown in Fig. 11 above, using a fast ($f/0.75$) reference lens, allows testing of azimuthal figure error. Again, only profiles are returned, and again this test is used on glass substrates for screening and to test replicated optic elements before integration into the OAP. As used for the in-situ measurements, this test has a significantly larger range of depths at which fringes can be seen in the interferometer video monitor than can be measured. However, this affords a means of getting from mechanical levels of azimuthal alignment to the optical level. Once aligned for optical testing, the azimuthal profile can be used to dictate which azimuthal adjustments are made. To view different axial locations on the mirror, the interferometer will be moved vertically.

3.3 OAP Assembly

The Primary Optic Housing (P1) for the OAP module as been assembled and the Optic Adjustment Arms have been installed. The P1 housing was fabricated and assembled at the NASA – Goddard Space Flight Center (GSFC). After all of the component parts and tooling were fabricated, the tooling was used to align the P1 housing pieces into their proper locations, as shown in Fig. 12 below. The large cylinder was used to establish the proper radial position for the sides of the P1 Housing and support them during the assembly process. The sides were then aligned such that they created the proper 60-degree section for the OAP module.



Fig. 12: OAP Primary Optic Housing assembly process.

Next, the struts onto which the Optic Adjustment Arms will be mounted were aligned to the P1 Housing sides. Again, the large cylinder determined the radial position and radiality of the struts. A height gage was then used to set the distance between the struts and their relative flatness to the granite reference table. The design of the OAP, and likewise

the P1 Housing, is such that high tolerances are not required. The only dimensional requirement on the OAP is that the optic elements must fit within the module sides and struts, thus easing the OAP module tolerances to about 0.005in in comparison to the tolerances required of the optic elements. After the struts were aligned, the remaining components for the P1 Housing were installed. The struts and component parts of the OAP P1 Housing can be seen in Fig. 13 below.



Fig. 13: OAP P1 Housing.

To facilitate such a delicate assembly and alignment process, a special assembly technique was used. The traditional method for building a structure such as the OAP would involve ‘match drilling’ the components for bolted joints. For match drilling, the component parts are clamped together and then boltholes are drilled. The drawback to this method is that extensive vibration and pressure is used that could alter the alignment of the structure. To resolve this issue, a mounting bushing bonding scheme was developed to enable the precision alignment of a bolted assembly such as the OAP. Essentially, oversized holes were drilled into a component that was to be mated to another. In the other part, a counterbored threaded hole was made that had a mounting bushing pressed into it. The holes in the mating part were then placed over the mounting bushings and the bushings were bonded to the mating part with epoxy, as shown in Fig. 14 below. A bolt was then placed through the bushing to secure the joint. For disassembly, the bolt can be removed so the bushing can be pressed out of its counterbore. The bushing will then be pressed back into the counterbore for re-assembly.

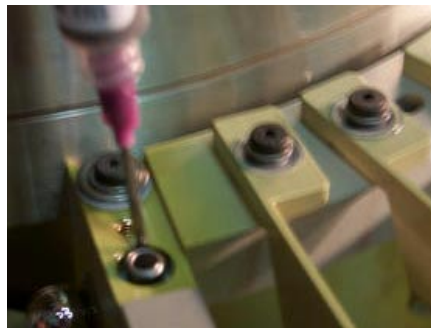

Fig. 14: Example of mounting bushing assembly technique.

Once all of the components for the OAP P1 Housing were assembled. The P1 Housing was removed from the large cylinder so the Optic Adjustment Arms and precision actuators could be installed as shown in Fig. 15 below.



Fig. 15: Complete OAP P1 Housing ready for optic integration.

The Secondary Optic Housing for the OAP module is currently being assembled. When it is completed, it will be mated with the Primary Optic Housing to complete the OAP module, which will then be ready for optic element integration and alignment.

ACKNOWLEDGEMENTS

The work described in this paper is a product of the Constellation-X SXT development team, which is a partnership between the NASA- Goddard Space Flight Center, the Smithsonian Astronomical Observatory, and the Massachusetts Institute of Technology. Though many of the contributors are recognized as authors of this paper, many others have provided input and services that have proven to be invaluable to this project.

REFERENCES

1. H. Bergner, *Segmented Optics Assembly*, Smithsonian Astrophysical Observatory Memorandum (1999)
2. P. Glenn, *Centroid Detector Assembly for the AXAF-I Alignment Test System*, *Proc. SPIE* 2515, 352 (1995)
3. L. P. Van Speybroeck, *Einstein observatory (HEAO-B) mirror design and performance*, *Proc. SPIE* 184, 2 (1979)